

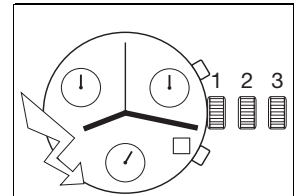

13 ¼" ETA G10.711

CT G10711 ESI 482189 06 11.01.2013

13 ¼" Ø 29,80 mm



Movement height	Altura sobre máquina	Altezza sopra movimento	5,62 mm
Height on battery	Altura sobre pila	Altezza sopra pila	5,62 mm
Number of jewels	Número de piedras	Numero di pietre	4
Frequency	Frecuencia	Frequenza	32'768 Hz

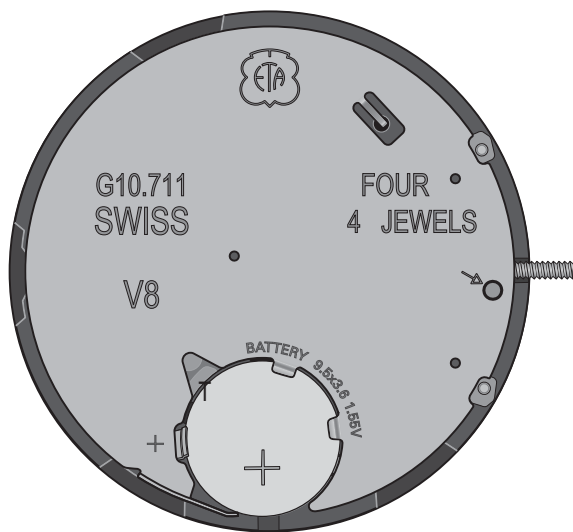

The repair and reconditioning work must only be performed by properly trained personnel.
 Las tareas de reparación y revisión sólo deben ser llevadas a cabo por personal debidamente formado.
 I lavori di riparazione e di revisione devono essere eseguiti esclusivamente da personale adeguatamente formato.



General information



Before starting work, please study this "Technical communication" carefully.



Eye protection is obligatory for all operations / work on the movement!



ETA SA disclaims any liability in case of damage arising from failure to observe this "Technical communication".

Environmental protection requirements



The legal provisions relating to waste handling and disposal must be observed in all operations / work on the movement!

In particular, lubricating and cleaning products harmful to the environment must be disposed of in accordance with the rules!



Substances prone to cause water pollution must be stored, transported, collected and disposed of in appropriate vessels.

Under no circumstances must they pollute the soil or be poured into sewage systems!

Explanation of symbols



Caution! Risk of material damage!

Below are some obligatory instructions for preventing any material damage!



Below are some instructions for telling which "Specific Information" must be observed.

Información general



Esta "Comunicación técnica" deberá estudiarse muy bien **antes** de comenzar los trabajos.



Es obligatorio utilizar protección ocular para todos los trabajos en y con el reloj.



ETA SA no se hace responsable de los daños provocados como consecuencia de la inobservancia de esta "Comunicación técnica".

Normas de protección medioambiental



Deberá cumplirse la normativa legal relativa al reciclaje y la eliminación correctos de los residuos en todos los trabajos en y con el reloj.

En especial, deberán eliminarse correctamente los productos lubricantes y de limpieza peligrosos para el medio ambiente.



Las sustancias contaminantes del agua deben recogerse, almacenarse, transportarse y eliminarse en recipientes adecuados.

En ningún caso se permitirá que contaminen el suelo o que lleguen a la canalización.

Significado de los símbolos



Atención Peligro de daños materiales

Instrucciones que deberán respetarse necesariamente para evitar daños materiales.



Instrucciones para saber qué "Información específica" deberá observarse.

Informazioni generali



Questa "Comunicazione Tecnica" deve essere studiata attentamente **prima** dell'inizio dei lavori.



Per tutti i lavori su e con il movimento dell'orologio è obbligatorio proteggere gli occhi!



ETA SA declina qualunque responsabilità per eventuali danni causati dalla mancata osservanza della presente "Comunicazione tecnica".

Disposizioni relative alla protezione ambientale



Per tutti i lavori su e con il movimento dell'orologio si dovranno rispettare le disposizioni di legge relative al corretto riciclaggio e smaltimento dei rifiuti!

In particolare si dovrà provvedere al corretto smaltimento di lubrificanti e detergenti nocivi per l'ambiente!



Le sostanze inquinanti per l'acqua devono essere conservate, trasportate, raccolte e smaltite in contenitori adatti.

Queste non devono inquinare il terreno o arrivare nelle canalizzazioni!

Spiegazione dei simboli



Attenzione! Pericolo di danni materiali!

Seguono importanti indicazioni che devono essere tassativamente rispettate per evitare danni materiali!



Seguono indicazioni su quali "Informazioni specifiche" devono essere rispettate.

List of components - Lista de piezas - Lista fornitori

Pos	No	No CS	Article number Número de artículo Numero articolo	List of components	Lista de piezas	Lista fornitori
1	405	51.020.21	Var	Handsetting stem	Tija de puesta en hora	Albero di messa all'ora
2	4929	20.570.00	7613226038554	Battery	Pila	Pila
			Var	Variante	Variante	Variant

**Interchangeability and variants
can be found on the
ETA ONLINE SHOP (EOS):**

www.eta.ch

- Support Center
- Support Center Portal

**La intercambiabilidad y las
variantes se encuentran en
ETA ONLINE SHOP (EOS):**

www.eta.ch

- Support Center
- Support Center Portal

**L'intercambiabilità e le varianti si
trovano sul
ETA ONLINE SHOP (EOS):**

www.eta.ch

- Support Center
- Support Center Portal

Materials - Fornituras - Forniture

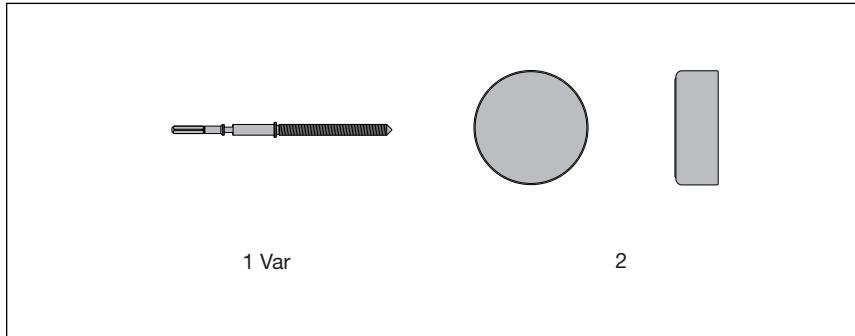

Spare parts - Piezas de repuesto - Pezzi di ricambio:

 **Movement undivisible !**
Movimiento no desmontable !
Movimento non smontabile !

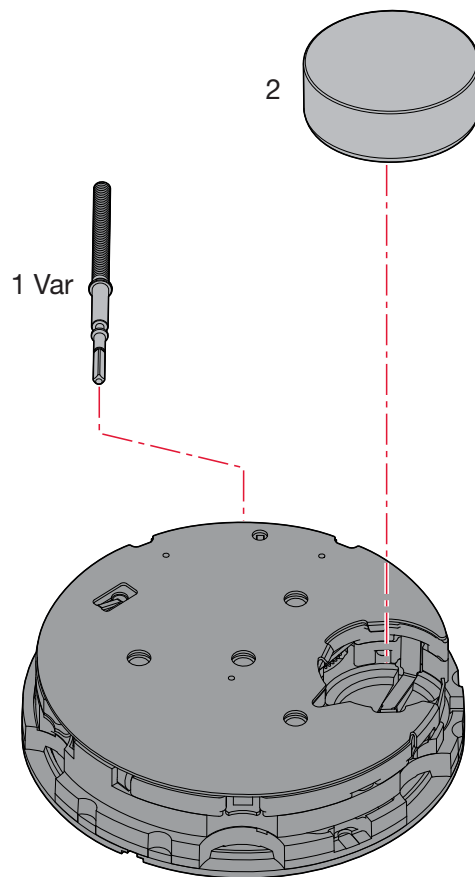

Electrical tests - Controles eléctricos - Controlli elettrici

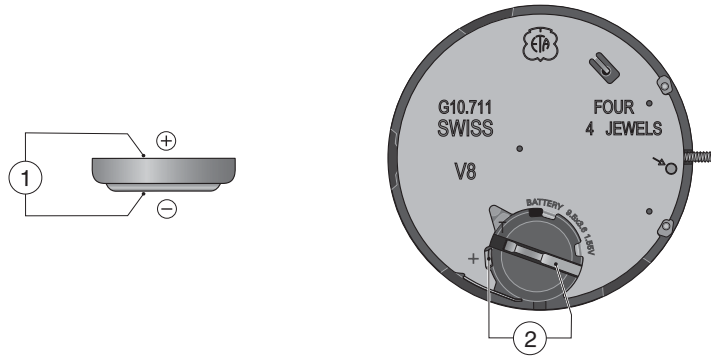

Position Posición Posizione	Setting of apparatus Escala de medición Scala di misura	Measurement Medición Misura	Test Control Controllo	Remarks Notas Osservazioni
1	2 V (Ri ≥ 10 kΩ/V)	1,55 V	Battery voltage Tensión de la pila Tensione della pila	< 1,5 V = Change the battery < 1,5 V = Remplazar la pila < 1,5 V = Sostituire la pila
2	2 V	≤ 1,30 V Measurement without battery, with variable external supply, starting with 1.55 V, lower tension until movement stops. Medición sin pila. Con alimentación exterior variable, bajando de 1,55 V hasta la parada de la máquina. Misura senza pila. Con alimentazione esterna variabile, scendendo da 1,55 V fino all'arresto del movimento.	Lower working-voltage limit. Movement, setting crown in pos. 1. 1/10 sec. counter, setting crown in pos. 2, pushbutton A (frequency 32 Hz). Seconds counter, setting crown in pos. 2, pushbutton B (frequency 32 Hz). Minutes counter, setting crown in pos. 3, pushbutton A (frequency 32 Hz). Limite inferior de la tensión de funcionamiento. Movimiento de base, corona en pos. 1. Contador 1/10 de segundo, corona en pos. 2, pulsador A (Frecuencia 32 Hz). Contador de los segundos, corona en pos. 2, pulsador B, (Frecuencia 32 Hz). Contador de los minutos, corona en pos. 3, pulsador A, (Frecuencia 32 Hz). Limite inferiore della tensione di funzionamento. Movimento di base, corona in pos. 1. Contatore 1/10 di secondo corona in pos. 2, pulsante A (frequenza 32 Hz). Contatore dei secondi, corona in pos. 2, pulsante B (frequenza 32 Hz). Contatore dei minuti, setting crown in pos. 3, pulsante A (frequency 32 Hz).	> 1,30 V = Exchange the movement. > 1,30 V = Remplazar el mecanismo. > 1,30 V = Sostituire il movimento.
			Impulses at output of integrated circuit: Impulsos a la salida del circuito integrado: Impulsi all'uscita del circuito integrato: 1/sec.	Measurement with battery. Medición con una pila. Misura con una pila.
		≤ 3,5 μA Normal mode Modo normal Modo normale	Consumption of movement, with stem in neutral position, measurement without battery, with external power supply 1.55 V. Consumo de la máquina con la tija en posición neutra, medición sin pila, con alimentación exterior de 1,55 V.	≤ 3,5 μA Normal mode Modo normal Modo normale
10 μA	≤ 6,5 μA Normal mode Modo normal Modo normale	Consumo del movimiento con l'albero in posizione in posizione neutrale, misura senza pila, con alimentazione esterna di 1,55 V.	≤ 6,5 μA Normal mode Modo normal Modo normale Exchange the movement Remplazar el mecanismo Sostituire il movimento	

The test must be conducted at an ambient temperature of between 20°C and 25°C.
Las pruebas deben realizarse a una temperatura ambiente comprendida entre 20°C y 25°C.
I test devono essere effettuati a temperatura ambiente compresa tra 20°C e 25°C.

Checking the instantaneous rate

Rate adjustment through inhibition.

Checking the instantaneous rate of the movement requires specialized equipment, capable of picking up and integrating impulses over one or several periods of 60 seconds.

Current supply

Silver oxide battery
U = 1.55 V, "Low Drain" type.

Ø 9.50 mm, height 3.60 mm

Capacity 84 mAh (Renata)

Renata, Varta, Energizer, Rayovac
No. 394, SR 936 SW.

Fitting the battery

Slide the battery under the two metal tabs of the module cover.

Press the battery firmly into its mounting. The finger of the module cover keeps the battery in position.

Removing the battery

Insert tweezers ① between maintaining finger and battery (see drawing) and pry out the battery by gently lifting back ② the module cover catch. Remove the battery ③.

Control de la marcha instantánea

Reglaje de la marcha por inhibición.

El control de la marcha de la máquina debe hacerse obligatoriamente con la ayuda de un aparato para captar los impulsos del motor que permita una integración de 60 segundos (o un múltiplo de 60 segundos).

Alimentación

Pila al óxido de plata.
U = 1,55 V, tipo "Low Drain".

Ø 9,50 mm, altura 3,60 mm

Capacidad 84 mAh (Renata)

Renata, Varta, Energizer, Rayovac
Nr. 394, SR 936 SW.

Colocación de la pila

Colocar la pila debajo de las dos lengüetas metálicas del cubre-módulo.

Apretar la pila al fondo de su alojamiento. El dedo del cubre-módulo sujeta la pila en su sitio.

Retiro de la pila

Colocar una pinzas ① entre el dedo de mantenimiento y la pila (veáse dibujo) y palanquear la pila apartando cuidadosamente el dedo del cubre-módulo ②. Sacar la pila ③.

Controllo della marcia istantánea

Regolazione della marcia per inibizione.

Il controllo della marcia del movimento si deve effettuare obbligatoriamente con un apparecchio che consenta di captare gli impulsi del motore con un'integrazione di 60 secondi (o un multiplo di 60 secondi).

Alimentazione

Pila all'ossido d'argento.
U = 1,55 V, tipo "Low Drain".

Ø 9.50 mm, altezza 3.60 mm

Capacità 84 mAh (Renata)

Renata, Varta, Energizer, Rayovac
No. 394, SR 936 SW.

Posa della pila

Far scivolare la pila sotto le due linguette metalliche del copri-módulo.

Premere la pila al fondo del suo alloggiamento. Il dito del copri-módulo mantiene la pila nella sua posizione.

Ritiro della pila

Far scivolare una pinzetta ① tra il dito di sostegno e la pila (si veda disegno) e fare leva sotto quest'ultima allungando leggermente il dito di sostegno verso dietro ②. Ritirare la pila ③.

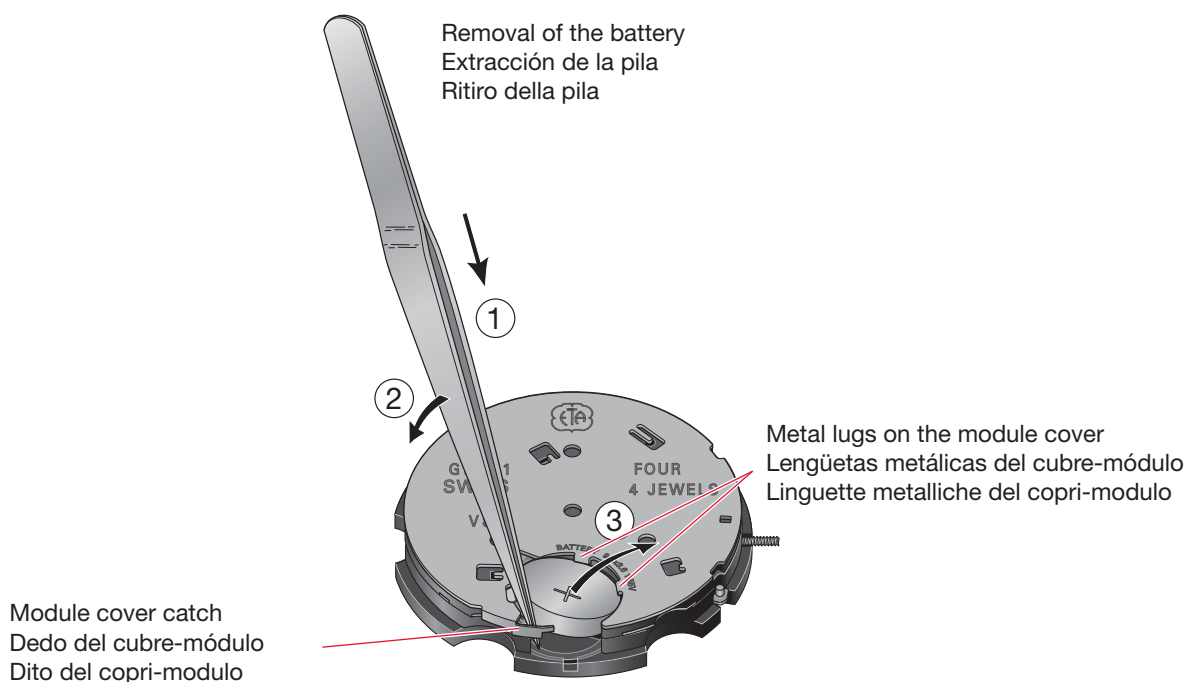

We reserve all rights for this document. It is meant for the recipient only and it may not be copied, printed or given to a third person without our written permission. Quedan reservados todos los derechos relacionados con este documento, que está dirigido únicamente al destinatario. Queda por lo tanto prohibida su copia, impresión a terceros sin nuestra autorización por escrito. Ogni diritto su questo documento è riservato. Il documento è indirizzato esclusivamente al destinatario e non può essere copiato, stampato o ceduto a terzi senza un'autorizzazione scritta.

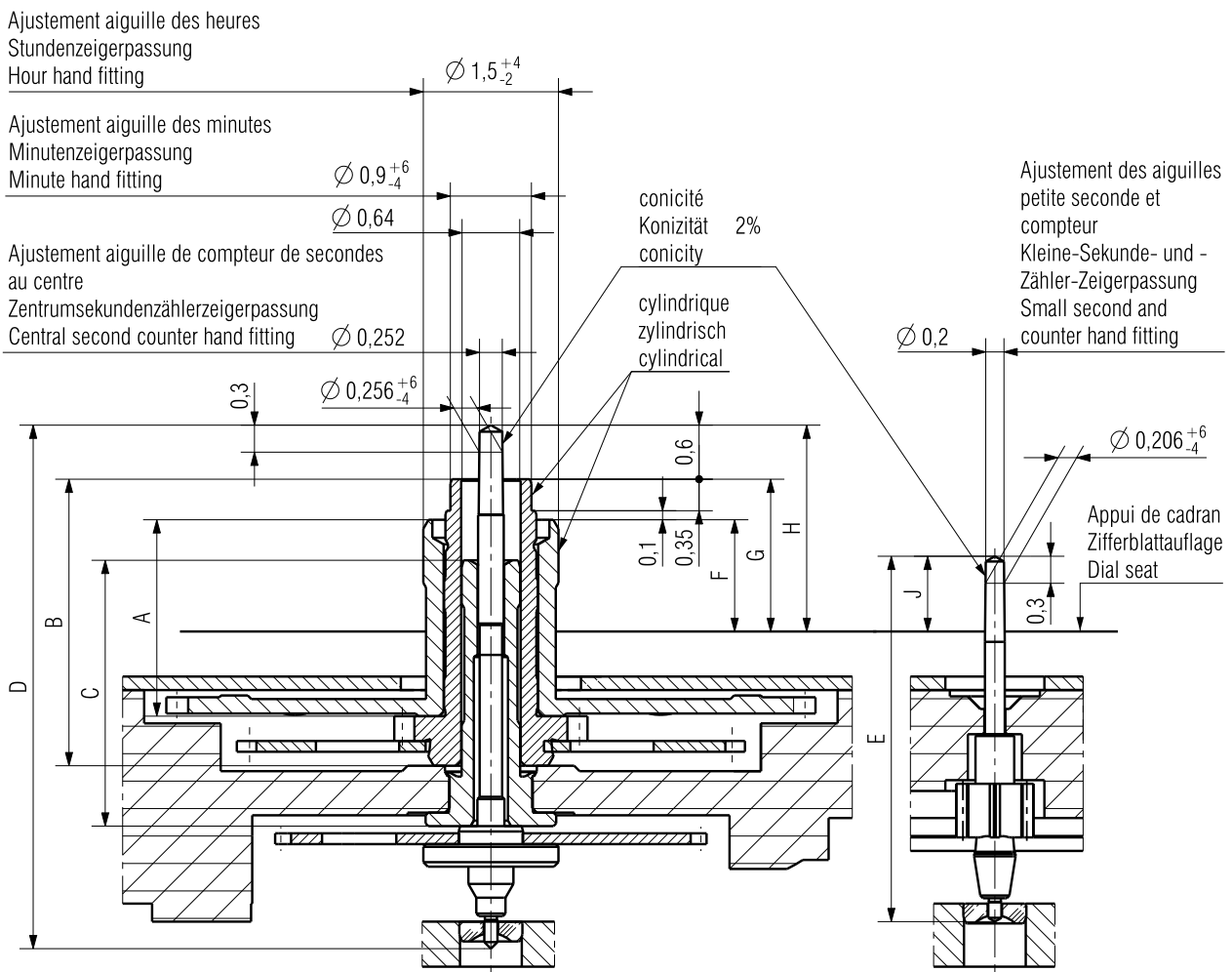

Aiguillage Zeigerwerkhöhe Hand fitting height	Longueur/Länge/Length									Dépassement Hohe über Zifferblattauflage Height over dial seat	
	A	B	C	D	E	F	G	H	J		
	Roue des heures Stundenrad Hour wheel	Chaussée Minutenrohr Cannon-pinion	Tube de centre Zentrumrohr Centre tube	Compteur de sec. au centre Zentrumsekundenzähler Central second counter	Roue de petite sec. et compteur Kleine-Sekunde und-Zähler-Rad Small sec. and counter wheel	Roue des heures Stundenrad Hour wheel	Chaussée Minutenrohr Cannon-pinion	Compteur de sec. au centre Zentrumsekundenzähler Central second counter	Roue de petite sec. et compteur Kleine-Sekunde und-Zähler-Rad Small sec. and counter wheel		
1	2,18	3,18	2,95	5,81	4,055	1,24	1,69	2,29	0,835		

Aiguilles Zeiger Hands		Aiguille des heures Stundenzeiger Hour hand		Aiguille des minutes Minutenzeiger Minute hand		Aiguille de compteur de sec. au centre Zentrumsekundenzählerzeiger Central second counter hand		Aiguille de petite seconde Kleiner Sekundenzeiger Small second hand		Aiguille de petit compteur Kleiner Zählerzeiger Small counter hand	
Masse/Masse/Mass	max.	mg	-	-	15	6	3				
Balourd/Unwucht/Unbalance	max.	μ Nm	-	3	0,05	0,05	0,025				
Inertie/Trägheit/Inertia	max.	gmm ²	-	-	0,15	0,15	0,15				
Force de chassage Setzkraft Press-in force	max.	N	40	40	40	25	25				

Kaliber / Calibre / Caliber G10.711/791		Massstab Echelle Scale --		CATIA V5
		Masse in mm Dimensions en mm Dimensions in mm Tol. 1/1000 mm		

AIGUILLAGES ZEIGERWERKHÖHEN HAND FITTING HEIGHTS		Z0503046		Version 00	Revision 00	Blatt Feuille Sheet 01/01
---	--	-----------------	--	----------------------	-----------------------	---

ETA SA MANUFACTURE HORLOGÈRE SUISSE DEPUIS 1793	Ersatz für/En remplacement de/Remplacement for 23.10.97/05.11.97		Klass. ZVACC		KUN	
	Aenderung/Modification		Erstellt Etabli Created 29.01.2009 ZWJ	Geprüft Contrôlé Controlled 29.01.2009 LAK	Freigegeben Libéré Released 30.01.2009 LAK	
A COMPANY OF THE SWATCH GROUP						

This page has deliberately been left blank in case of A3 format printing.

Esta página se han dejado en blanco a propósito en caso de imprimirla en formato A3.

Questa pagina è lasciata intenzionalmente bianca in caso di stampa formato A3.

This page has deliberately been left blank in case of A3 format printing.

Esta página se han dejado en blanco a propósito en caso de imprimirla en formato A3.

Questa pagina è lasciata intenzionalmente bianca in caso di stampa formato A3.

This page has deliberately been left blank in case of A3 format printing.

Esta página se han dejado en blanco a propósito en caso de imprimirla en formato A3.

Questa pagina è lasciata intenzionalmente bianca in caso di stampa formato A3.

Modifications compared with previous document versions**Modificaciones comparadas con las versiones anteriores del documento****Modifiche comparate con le versioni precedenti del documento**

Version Versión Version	Date Fecha Data	Modification	Modificación	Modifica	Page Página Pagina
06	11.01.2013	New address	Nueva dirección	Nuovo indirizzo	1, 3, 12
		New illustration	Nueva ilustración	Nuova illustrazioni	5
05	06.05.2010	Modification impulses	Modificación impulsos	Modifica impulsi	6
		Spare parts	Piezas de repuesto	Pezzi di ricambio	5
04	02.09.2008	New layout	Nuevo layout	Nuova layout	1-8
		Allocation per caliber	Asignación por calibres	Ripartizione per calibri	--
03	11.04.2006	New layout	Nuevo layout	Nuova layout	1-8
02	13.09.2004	Basic version	Versión de base	Versione di base	--

All modifications reserved.

Salvo modificación.

Con riserva di ogni eventuale modifica.

This document can be found on the Support Center Portal (SCP):**www.eta.ch**

- Support Center
- Support Center Portal
- Technical Documents

Este documento se encuentran en el Support Center Portal (SCP):**www.eta.ch**

- Support Center
- Support Center Portal
- Technical Documents

Il presente documento si trovano sul Support Center Portal (SCP):**www.eta.ch**

- Support Center
- Support Center Portal
- Technical Documents



ETA^{SA}
 MANUFACTURE HORLOGÈRE SUISSE
 DEPUIS 1793

SC PRODUCT COMMUNICATION

Bahnhofstrasse 9
 2540 Grenchen
 Switzerland

Phone +41 (0)32 655 71 11
 Fax +41 (0)32 655 71 74

contact@eta.ch
 www.eta.ch